

GRReddy®

***GR*Reddy Turbo Kit**

Mitsubishi Eclipse GSX, GST, Spider GST (4G63)



TRUST SUPER TUNING SYSTEM

TOTAL TUNE UP.

AIMING AT REAL COMPETITIONS.

TRUST

Mitsubishi Eclipse GSX, GST, Spider GST (4G63)

Installation Manual

Please read the entire manual before installing this kit.

Application:

Make	Model	Chassis	Year
Mitsubishi	Eclipse	D32, D33, & D34	95 ~ 97

- This **GReddy Turbo Kit** is designed only for the vehicles specified above.
- This **GReddy Turbo Kit** is a complete bolt on replacement and once installed, it is ready to use. For optimum performance it is highly recommended to also install the **GReddy Type-S Blow-off Valve**, the **GReddy Pipe Set**, the **GReddy Airinx Kit** and especially the **GReddy Intercooler Kit** for Mitsubisni Eclipse.

Eclipse Turbo Kit

1. Parts List

1.	TDO5H-18G 7cm ₂ / Actuator type P765				1
2.	Turbo Adapter (Flange Spacer)				1
3.	GReddy "High Flow" Suction Pipe (Alumi. Elbow) 100Ø-80Ø				1
4.	35Ø Blow-off valve return pipe (steel)				1
5.	Turbo oil pressure hose (SUS 600)				1
6.	Turbo oil pressure union (3/8 pt – 1/8 pf)				1
7.	Turbo oil pressure banjo union 10Ø male-female				1
8.	Copper washer 10Ø				2
9.	Oil return flange tube #1 16Ø				1
10.	Oil return flange tube #2 16Ø				1
11.	100Ø Silicone hose 60mm				1
12.	80Ø Silicone hose 60mm				1
13.	34Ø Silicone hose 40mm				1
14.	90Ø Spacer rubber hose 30mm				1
15.	16Ø Oil return hose 17mm				1
16.	5Ø Actuator hose 1000mm				1
17.	100Ø Hose band #60				2
18.	80Ø Hose band #48				2
19.	35Ø Hose band #20				4
20.	16Ø Hose band #8				2
21.	Turbo adapter gasket				2
22.	Down-pipe Adapter gasket #1 (turbine side)				1
23.	Oil return gasket				2
24.	Plug fitting M14 P=1.5mm w/ copper washer				1
25.	Plug fitting copper washer 14Ø				1
26.	Plug cap 10Ø				1
27.	Rubber Plug 5Ø				2
28.	3 Way joint 5Ø				1
29.	Tie Wrap 150				5
30.	M10 x 90mm P=1.25 (heat-treated cap bolt)	B	-	-	4
31.	M10 x 45mm P=1.25 (stainless stud)	B	S/W	F/W N	1
32.	M10 x 35mm P=1.25 (stainless bolt)	B	S/W	F/W N	3
33.	M6 x 15mm P=1.0 (stainless steel)	B	S/W	- -	2

Parts List

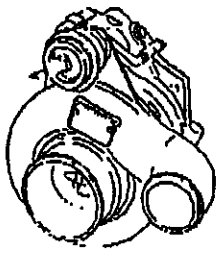

1



2

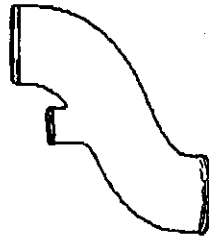

3

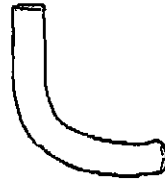

4

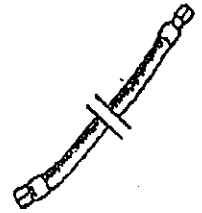

5



6



7

8



9



10



11



12



13



14



15



16



17

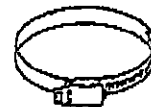

18



19



20

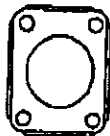

21



22



23



24



25



26



27



28



29



30



31

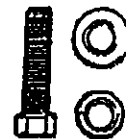

32



33

2. Removal of Stock Parts

2-1 Stock Parts Removal

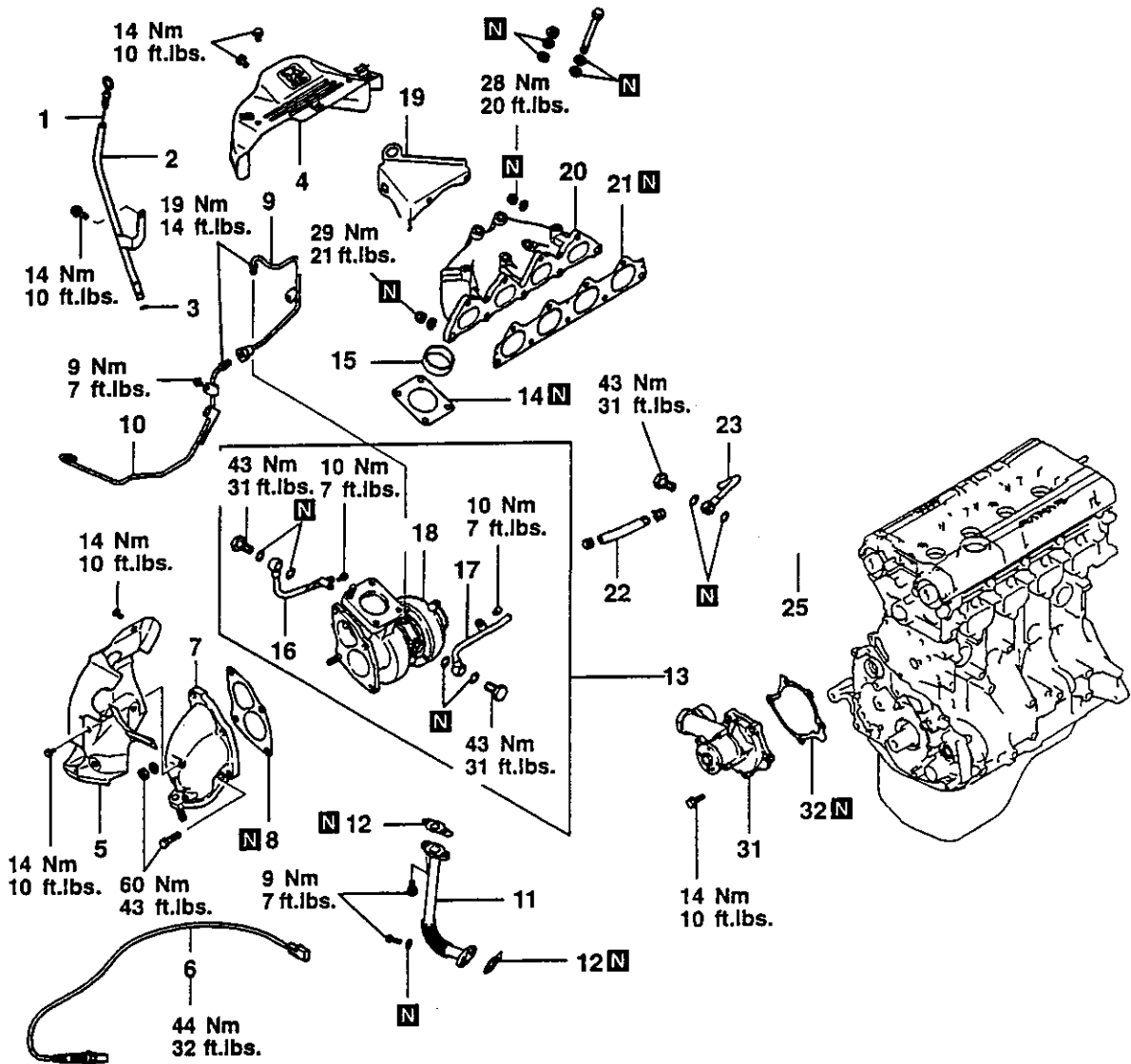

1. Oil dipstick
2. Oil dipstick guide
3. O-ring
4. Heat protector "A"
5. Heat protector "B"
6. Heated oxygen sensor
7. Exhaust fitting
8. Gasket
9. Oil pipe "A"
10. Oil pipe "B"
11. Oil return pipe
12. Gasket
13. Turbocharger assembly
14. Gasket
15. Ring
16. Water pipe "A"

17. Water pipe "B"
18. Turbocharger
19. Engine hanger
20. Exhaust manifold
21. Gasket
22. Water hose
23. Water pipe "C"

2-2 Stock parts Removal Procedure

1. Disconnect negative terminal of the battery.
2. Drain oil and coolant.
3. Disconnect the air flow meter connector and remove the stock air filter box. Disconnect the blow-off valve return hose, breather hose and purge hose from the canister. Remove the air intake hose.

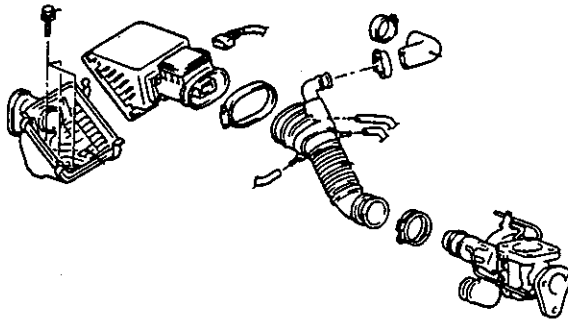

4. Disconnect the O2 sensor connector.
Remove the stock turbocharger assy.
Disassemble the turbocharger assy.
Remove the water pipe assy.
Remove all the stock turbo oil pipe assy.
Remove the stock turbo oil return pipe.
Remove the down adapter.

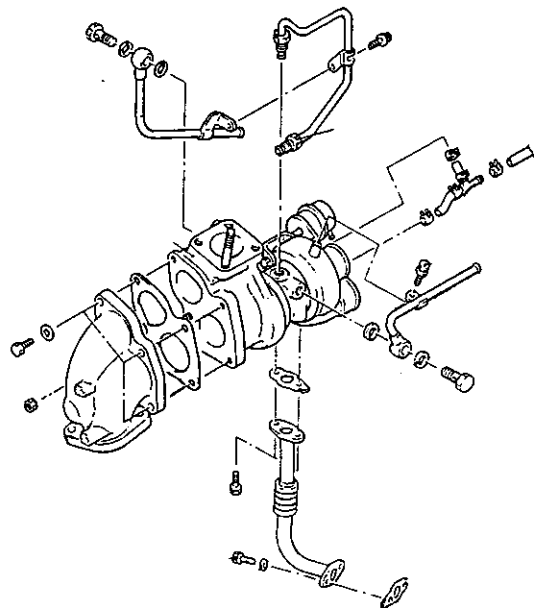
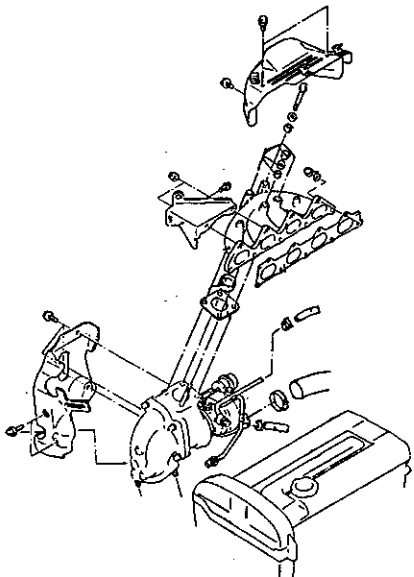

3. GReddy Turbo Kit Installation

3-1.1 After removing the stock turbo water line, plug up the feed and return holes.

3-1.2 On the engine block side, use the supplied plug fitting and copper washer to seal the water feed. (as shown in the picture)
Part used: # 24, 25

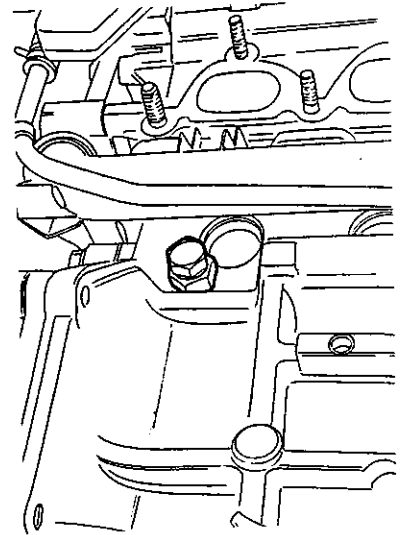

3-1.3 On the pipe side, cut about 3 cm (1 ¼ in.) of the factory hose and use the plug cap provided to plug up the pipe. (Use stock hose clamps.) (as shown in the picture)
Part used: # 26

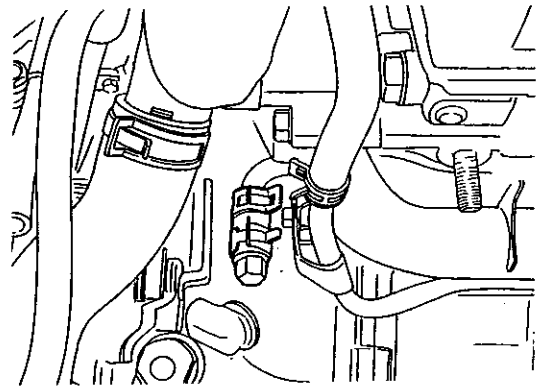

3-2 Plug up the stock boost controlling solenoid valve with the provided rubber caps. (as shown in the picture)
Part used: # 27

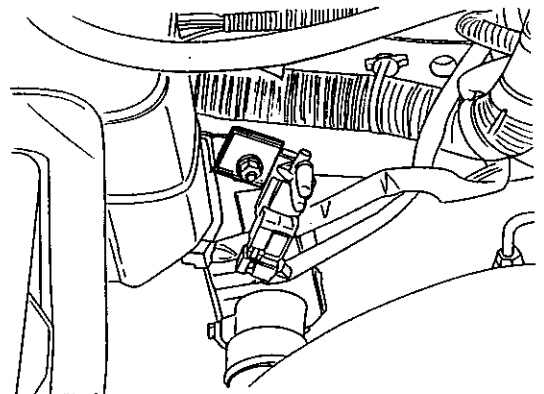

- 3-3.1 Bolt up the stock down-pipe adapter to the GReddy TD05H – 18G Turbo Charger using provided hardware and gasket.

Parts used: # 22, 31, 32

Bolt the turbocharger assy. to the stock exhaust manifold using the provided adapter flange, two gaskets, and bolts.

(Use stock washers)

Part used: # 1,2, 21, 30

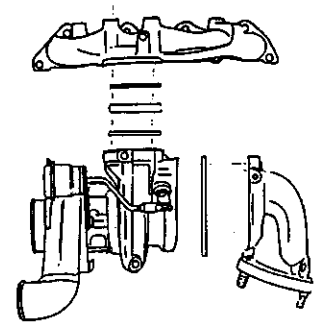

- 3-3.2 Install turbo oil pressure line to the turbocharger using banjo fitting.

(as shown in the picture)

Parts used: # 5, 7, 8

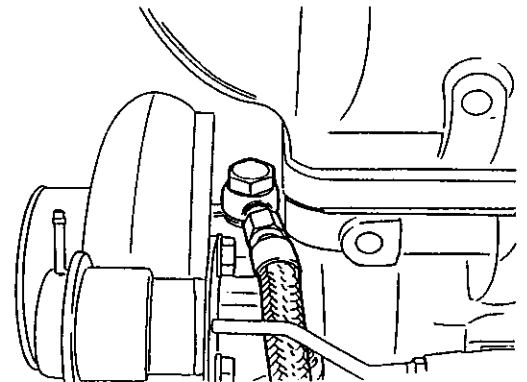

- 3-3.3 Install the turbo oil return pipe to the turbocharger.

Part used: # 9, 24, 33

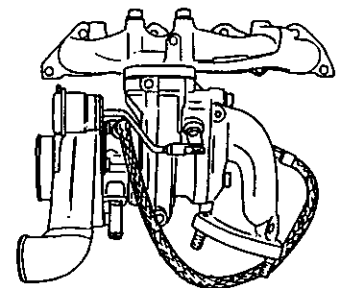

- 3-4.1 Cut the shaded area of stock heat shield.

(as shown in the picture).

Make sure the actuator, at full open condition, has good clearance between the actuator rod and the heat shield.

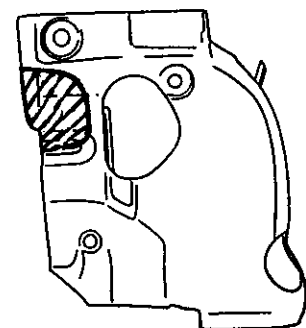

3-4.2 Bolt on the heat shield to the turbocharger Assy. Then install the turbocharger assy. onto the cylinder head. Use all stock hardware. Use new exhaust manifold gasket. (Not included)

3-5 Install the turbo oil pressure union fitting to the oil filter block. (Where the stock turbo oil pressure line was connected to) (as shown in the picture)
Part used: # 6

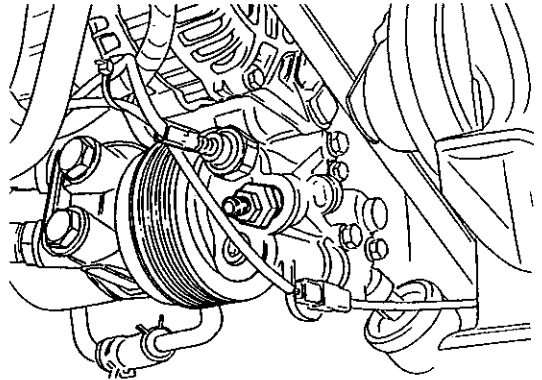

3-6 Connect the turbo oil pressure line from the turbocharger to the turbo oil pressure union fitting, and tie wrap the line to the condenser fan frame (as shown in the picture)
Part used: #29

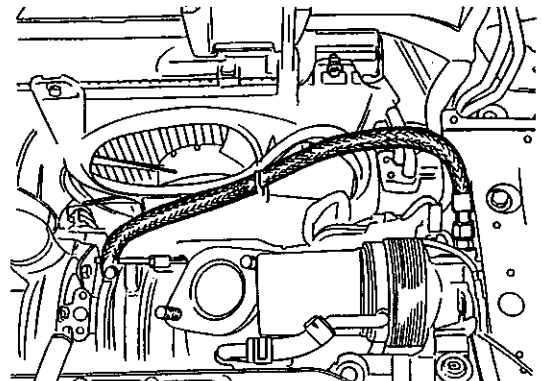

3-7.1 Install the turbo oil return pipe to the oil pan using the provided gasket and by using the stock bolts and aluminum washer. Replace the aluminum washer if damaged
Parts used: #10
(as shown in the picture)

3-7.2 Install the oil return hose with the provided hose and hose band from turbo to the oil pan.
Parts Used: #15, 20

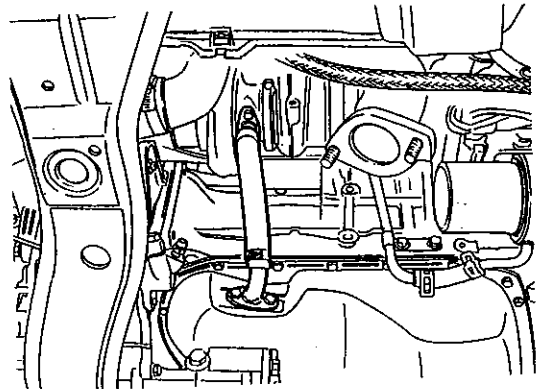

- 3-8 Reinstall the stock down pipe with the stock gasket. By using the turbo adapter flange the turbocharger position has dropped about 15 mm.

In order to line up the mounting bracket;

1. Loosen up the bolt shown with an arrow
2. Move up the mounting bracket to line up to the bracket on the engine block.
3. Tighten up the mounting bolts.

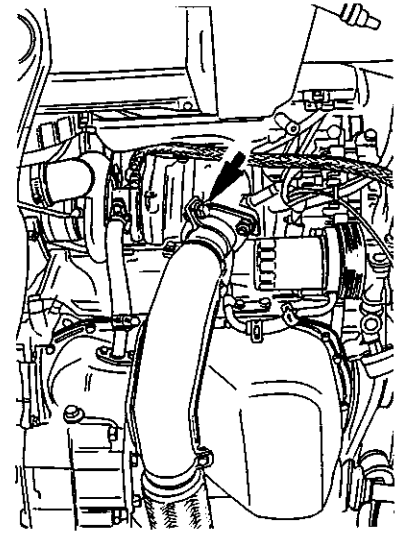

- 3-9 Reinstall the compression pipe from the turbo to the intercooler. Use stock hose or the GReddy Pipe Set (as shown in the picture)

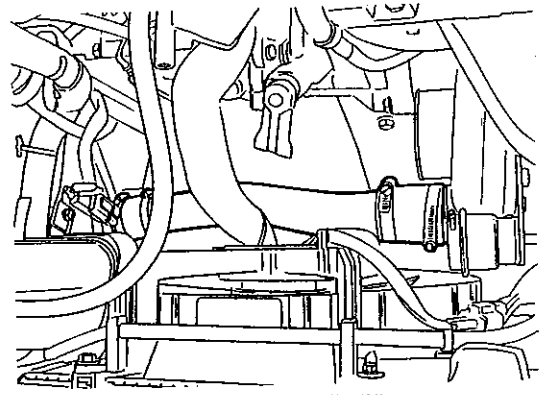

- 3-10.1 Install the Air-flow meter rubber spacer over the out let of the air-flow meter.

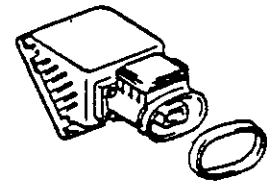

- 3-10.2 Install the GReddy "High-Flow" Suction Pipe using the provided hoses and hose clamps.

Connect the breather hose from the valve cover and the purge hose from the emissions canister to the GReddy "High-Flow" Suction Pipe.

(As shown in the picture)

Parts used: # 3, 11, 12, 17, 18

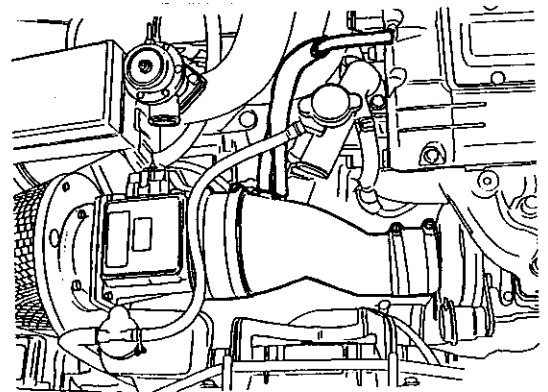

- 3-11 Cut the Stock blow-off valve return hose.
(as shown in the picture)

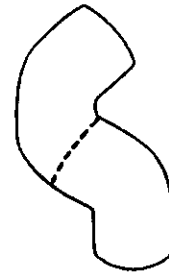

- 3-12 Install the blow-off valve return pipe using the upper portion of the cut hose and the provided hose from blow-off valve to the bottom of the GReddy "High-Flow" Suction Pipe.
(as shown in the picture)
Parts used: # 4, 13, 19

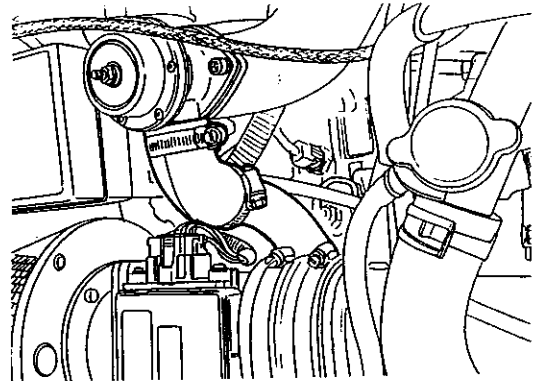

- 3-13 Connect the vacuum hose from turbo actuator to the vacuum line between the intake manifold and the fuel pressure regulator solenoid valve.
Parts used: # 16, 28
(as shown in the picture)

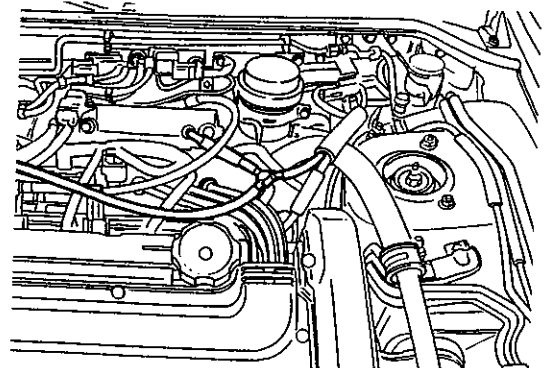

- 3-14 Reconnect the negative terminal of the battery.

- 3-15 Refill the engine oil and coolant.

- 3-16 Disconnect the ignition coil power transistor and cam position sensor connector. With the vehicle on a level surface, crank the engine to get oil pressure in the turbocharger. Crank until oil pressure indicator lamp turns off.

3-17 Reconnect the power transistor and cam position sensor connector. Start the engine and check for any oil, and air leaks.

